

PROCON™ MINI XLR

Product sheet
PROCON™ Mini XLR

V3.1, 2023-12-05

AB Micropol Fiber optic
Älvdalsvägen 4
313 50 Åled

Phone: +46 (0)35 17 85 39
Mail: info@micropol.com

The PROCON connectors offers a good attenuation. With an insertion loss of <1,5 dB it outperforms the NATO specification (<2,5 dB).

The PROCON Mini XLR is one of the smaller expanded beam connectors available on the market today. The low profile allows it to be used even in the most cramped environments and installations.

PROCON has the advantage of being produced inhouse in Åled, Sweden which also means a stable delivery performance and we are able to promise shorter leadtimes.

Like the other connectors in the Micropol PROCON expanded beam family, it is compatible with other mini sized expanded beam connectors on the market.

FEATURES

- Insertion loss <1,5 dB
- Temperature range -57°C – +85°C
- Hermaphroditic interconnection
- Rugged connector design
- Keyed boot for blind mating
- No adaptors needed
- Easy clean, no special tools

COMPATIBLE WITH:

FIBRECO - MINI 2

QPC Q - MICRO

TE PRO-BEAM - MINI

TELECAST MX - MINI

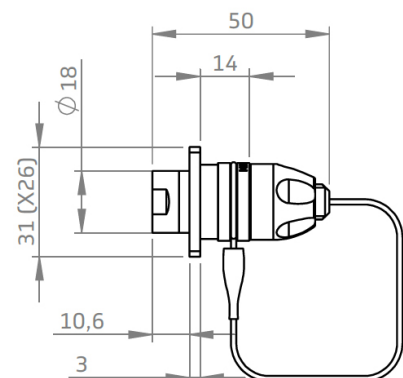
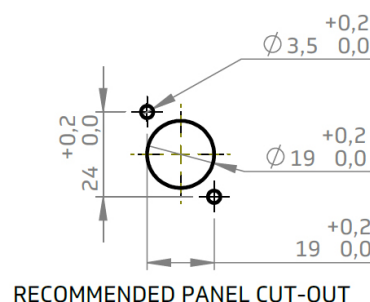

PROCON™ MINI XLR

Standard configurations

PROCON™ MINI | 1 to 4 channels

Optical

Type | Single mode (SM), multimode (MM) or hybrid

Transmission | 10Gbit/s

Insertion loss (SM) | Typical Insertion Loss -1,0dB (1310 nm)
Maximum Insertion Loss -1,5dB (1310 nm)

Insertion loss (MM) | Typical Insertion Loss -1,0dB (1300 nm)
Maximum Insertion Loss -1,5dB (1300 nm)

Return loss (PDL) | >35dB at 1310nm or 1550nm
Polarization dependent loss less than 0,5dB

Mechanical

Coupling type | Hermaphroditic
Compliant | ROHS & REACH
Material | Hard anodized aluminum
Alternative material | Marine bronze, stainless steel or titanium
Colour | Grey
Durability | 3000 mating cycles
Free fall | 500 falls from 1,2 meters height
Vibration | 5-500Hz, 0,75mm amplitude at 10G
Shaking | 390 m/S numbers of shakes 3x4000
Shock pulse length | 11ms, half sine at 35g
Numbers of axis: 3 (x, y, z)
Recommended wall thickness | 2-3 mm - not valid for cable plug JR and Mini

Environmental

Operating temperature | -57°C to +85°C,
Water immersion | IP67
Air pressure | <25kPa -55°C during 4h
Corrosion resistance | 500h salt spray
Flammability | DOD-STD-1678, method 5010